

Optoelectronic Feedback Control Techniques for Linear and Switch Mode Power Supplies

INTRODUCTION

The power supply designer is continually being pressured to provide units which have higher efficiency, better regulation, less EMI and RFI, and smaller size and weight, all at a lower cost. The solution to this problem is a combination of circuit topology, layout, and supply control. This application note will address output control techniques for linear and switch mode power supplies (SMPS). Specifically, it will cover control techniques using standard phototransistors and a new family of linear optocouplers.

ISOLATED REGULATION

National and international safety agencies require a supply's output to be isolated and insulated from the AC mains. Many supply manufacturers have elected to offer power supplies that satisfy all national and international safety insulation criteria by selecting power transformers and feedback devices that meet a 3750 V_{AC} withstand test voltage. Feedback systems that use optocouplers easily comply with this insulation criteria. Optocouplers also offer a high degree of noise rejection or isolation combined with their insulation characteristics.

LINEAR POWER SUPPLY FEEDBACK

Linear power supplies comply with the main insulation and isolation safety requirements by virtue of the primary/secondary insulation of the power transformer. There are numerous circumstances where isolated feedback in a linear power supply is needed, such as monitoring high-voltage power supplies, current measurement in the high side of the supply, or monitoring multiple isolated outputs. Figure 1 shows a typical block diagram.

The feedback system for a linear power supply should be DC transparent and continuous. A standard phototransistor coupler, when properly specified, can perform the feedback function. To properly specify the phototransistor it is important to review the elements that contribute to a coupler's operation. Figure 2 shows the phototransistor optocoupler schematic.

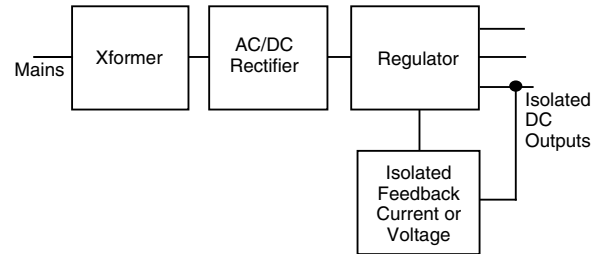

Originally presented at the PCIM®/Power Quality®, 1993 Conference, Irvine, CA, U.S.A.

17832

Fig. 1 - Linear Power Supply Phototransistor Model

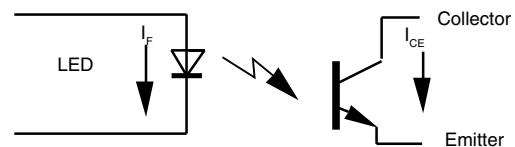

A. Simple Phototransistor

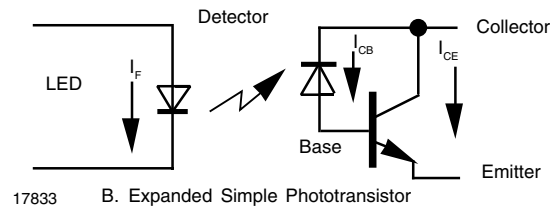

17833

B. Expanded Simple Phototransistor

Fig. 2 - Phototransistor Coupler Schematic

Phototransistor optocouplers are current amplifiers. These couplers include an infrared light emitting diode, LED, and an NPN silicon phototransistor. Figure 2A shows the common schematic of a standard phototransistor optocoupler. Figure 2B is an expanded schematic that includes a collector-base photodiode. An input LED current, I_F , creates an optical flux, which is detected by the photodiode. The photodiode develops a photocurrent, I_{cb} , which is amplified by the phototransistor. The phototransistor supplies a collector-emitter current, I_{ce} . The current gain of the device is defined as a current transfer ratio (CTR) and is expressed as a percentage. The CTR relationship is given in equation 1:

$$CTR = \frac{I_{ce} \times 100 \%}{I_F} \quad (1)$$

The relationship of the LED forward current flux creation and the generation of photocurrent is called current transfer ratio collector-base (CTR_{cb}). See equation 2.

$$CTR_{cb} = \frac{I_{cb} \times 100 \%}{I_F} \quad (2)$$

Combining equation 2 with the transistor current gain, h_{FE}, provides a more complete optocoupler gain equation:

$$CTR = \frac{I_{cb} \times 100 \%}{I_F \times h_{FE}} \quad (3)$$

The relationship given in equation 3 can be shown in a block diagram of the four elements that make up the DC transfer function of the phototransistor coupler. These elements are shown in figure 3.

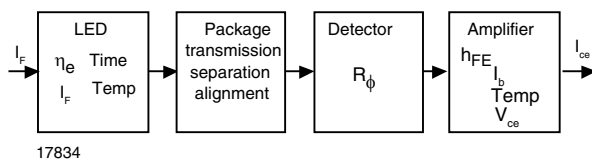

Fig. 3 - Phototransistor Block Diagram

The LED, package, detector, and transistor components have independent variables contributing to the optocoupler transfer function. The performance of the LED is influenced by four variables. These include the LED's external quantum efficiency, η_e, the forward current, I_F, junction temperature, T_J, and the total operation time.

The LED's external quantum efficiency, η_e, specifies the electrical-to-optical conversion factor. The optimum efficiency is determined by LED construction. For example, a GaAs LED has an η_e of approximately 10 %, while the η_e for a AlGaAs LED may be as high as 30 %. The operational LED efficiency is determined by the three remaining variables. The two most important are junction temperature and LED current. The LED's η_e has a negative temperature coefficient, typically - 1 %/°C. Figure 4 shows the temperature dependence. This figure shows that when the LED junction experiences a 50 °C temperature change, for example, from 25 °C to 75 °C. The output of the LED may be reduced by as much as 50 %. The temperature characteristic is more pronounced at a lower LED drive current. As the LED current is increased this coefficient may fall to - 0.5 %/°C.

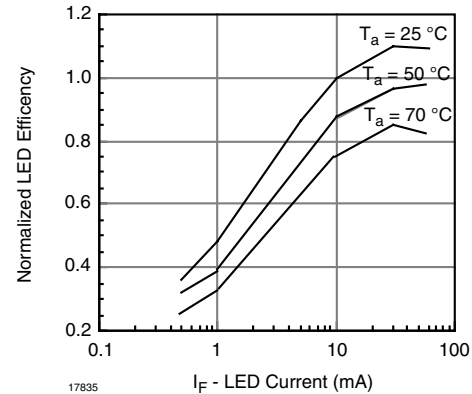

Fig. 4 - Normalized LED Efficiency

The influence of forward current on LED efficiency is also shown in figure 4. Note that a standard GaAs LED efficiency will be reduced by 50 % when the LED current is changed from 10 mA to 2 mA. One can conclude that in a DC circuit designs, the LED introduces large variations as a function of forward current and junction temperature.

Today's LED processing techniques have all but eliminated efficiency reduction as a function of time. LED efficiency reduction is commonly called CTR degradation. Typical degradation is less than 10 % at 10 k/h and increases at a logarithmic rate.

The second element is the optical coupling (K_φ) within the package. Numerous assembly techniques exist for creating the LED-photodiode coupling path. However manufacturing variations introduce coupling deviations, such as optical transmission media, emitter-detector separation distance, and alignment. K_φ is set at the time of manufacturing and is constant as a function of time and temperature.

The third element is the phototransistor's collector-base photodetector responsivity. This factor is the most consistent and linear element of the coupler. Process variations introduce worst case responsivity, R_φ, variations of less than 25 %. The nonlinearity of the detector, over the designed photocurrent range, is less than ± 0.1 %.

The fourth element is the phototransistor current gain, h_{FE}. The typical DC current gain showing the temperature, collector current, and V_{CE} influence on DC current gain is illustrated in figure 5. Note that Vishay phototransistors do not exhibit the typical beta peak found at low (< 1 mA) collector currents. It shows a typical h_{FE} temperature coefficient of + 0.5 %/°C. The most noticeable is the influence that V_{CE} has on current gain. Figure 5 shows that the saturated gain (V_{CE} < 0.4 V) is reduced by 30 % for an LED current of 10 mA.

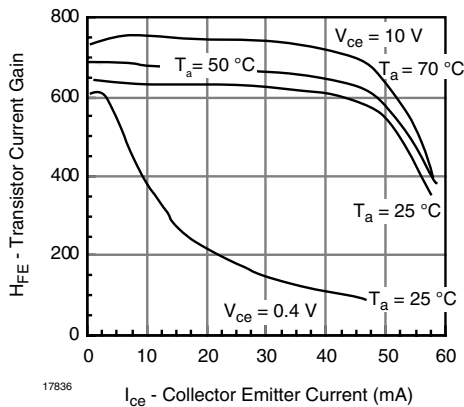

Fig. 5 - Phototransistor H

These four optocoupler elements create a linear DC transfer function, implying that a change in any one of these elements creates a factored change at the output. Functionally, the relationship is shown in equation 4:

$$I_{CE} = I_F \cdot [\eta_e(I_F, T_J, \text{time})]$$

$$K_\phi(T, A, S) \cdot R_\phi \cdot HFE(I_b, T_J, V_{CE})] \quad (4)$$

This section has presented the basic DC model and resulting transfer equation of the standard phototransistor. The goal was to illustrate factors that effect the DC current gain. The designer is encouraged to review the characteristics of the optocoupler being considered and be aware of the temperature and LED current influences on the current transfer ratio of a simple phototransistor.

Most designers compensate for these variations by selecting narrow-binned CTR optocouplers. Designers often compensate for gain variations by introducing negative feedback within a control loop. Equation 4 illustrates that typical voltage or current feedback techniques are not possible if insulation or noise isolation is to be maintained.

OPTICAL FEEDBACK CONTROL TECHNIQUE

The factors that influence the DC current gain of the optocoupler can be compensated by introducing optical feedback within the LED or input side of the coupler. This technique consists of including an optical detector or photodiode on the input that monitors the LED's output flux, which is possible now with the introduction of the Vishay family of linear optocouplers.

A DC coupler optical isolation amplifier using the new IL300 linear optocoupler is shown in figure 6.

This optical isolation amplifier uses an operational amplifier (U1) as an electro-optical servo amplifier that controls the LED current. The servo photodiode is operated in the photovoltaic mode and is zero biased from its connection to U1's inverting and non-inverting inputs.

This circuit responds to positive unipolar voltages, as found at the voltage output of the power supply. Initially, when the power supply is energized, $V_{in} = 0$ V, I_F and I_{P1} are also zero. As the input voltage rises, U1 forces a voltage across the LED causing it to emit light. The LED's optical flux generates a servo photocurrent (I_{P1}) which is proportional to the input voltage, $I_{P1} = V_{in}/R1$. The LED's current increases until sufficient servo photocurrent is generated to keep the difference between U1's inverting-noninverting inputs equal to zero volts.

The servo photocurrent is proportional to the LED's current. This relationship is defined as servo gain, $K1 = I_{P1}/I_F$. Combining the two equations describes the LED's current dependence on input voltage:

$$I_F = \frac{V_{in}}{K1 \times R1} \quad (5)$$

The isolated output circuit consists of a zero-biased photodiode transresistance amplifier. This output amplifier is configured to generate an output voltage proportional to I_{P2} and the transresistance R2. The output photocurrent, I_{P2} , is determined by the output transfer gain, $K2 = I_{P2}/I_F$. The output gain equation is $V_o = I_{P2} \cdot R2$. Solving for LED current by combing the preceding equations results in:

$$I_F = \frac{V_o}{K2 \times R2} \quad (6)$$

The composite DC transfer function of the input and output amplifiers can be determined when the equations 5 and 6 are combined resulting in the voltage gain equation:

$$\frac{V_o}{V_{in}} = \frac{K2}{K1} \times \frac{R2}{R1} \quad (7)$$

For simplicity, the ratio of $K2/K1$ is defined as the transfer gain, K3. The transfer gain can be rewritten as:

$$\frac{V_o}{V_{in}} = K3 \times \frac{R2}{R1} \quad (8)$$

The coupler's transfer gain (K3) is determined by the bifurcation of the LED's optical path within the coupler package. The time, temperature, and LED current have little effect on the transfer gain (figure 7).

Optoelectronic Feedback Control Techniques for Linear and Switch Mode Power Supplies

Vishay Semiconductors

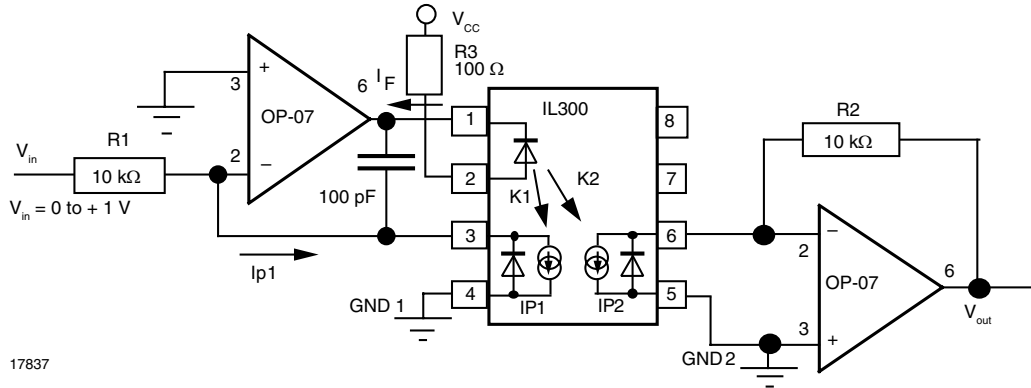

17837

Fig. 6 - Optical Feedback Amplifier

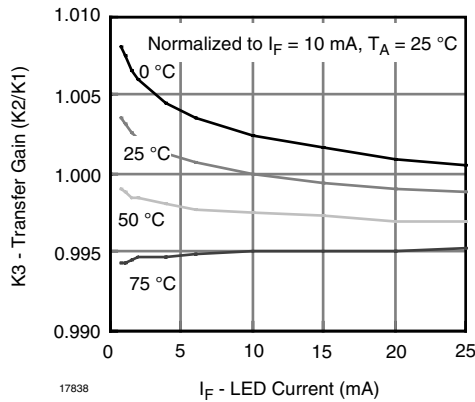

17838

Fig. 7 - IL300 Transfer Gain, K3

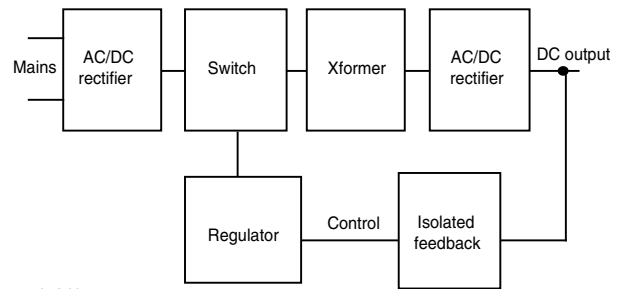

17840

Fig. 9 - SMPS Block Diagram

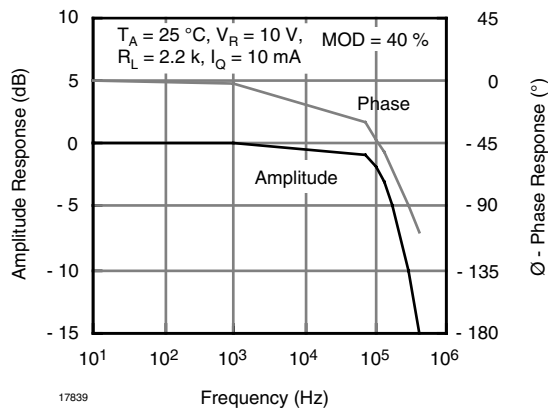

17839

Fig. 8 - IL300 Frequency and Phase Response

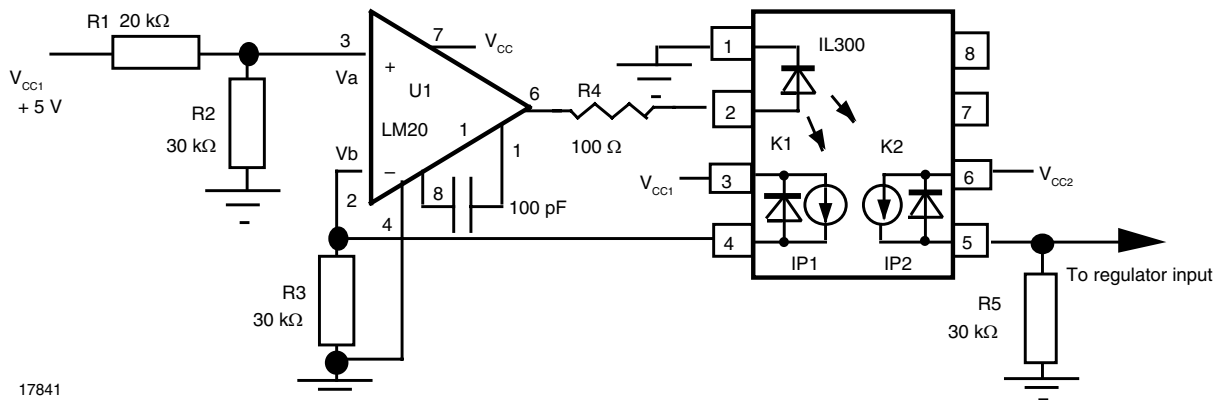

Fig. 10 - + 5 V Isolated Feedback Amplifier

Figure 7 shows that the IL300's gain typically varies by only $\pm 0.2\%$ over an LED current range of 5 mA to 20 mA, and has a temperature stability of ± 50 ppm/ $^{\circ}\text{C}$.

Figure 8 shows the frequency and phase response curve that shows the -3 dB point and a phase shift of 45° occur at a frequency in excess of 100 kHz.

The optical feedback technique greatly improves the main characteristic needed for a feedback amplifier used in a linear power supply.

MAINS ISOLATED SWITCHING POWER SUPPLY

Today's mains connected switch mode power supplies require an insulated and isolated output voltage control method. Standard phototransistor optocoupler are one of the various techniques used to effect this regulation. With the goal of high switching frequencies, the use of phototransistors is being pushed to its frequency response limits. Most power supply designers have found that gain and phase flatness can only be assured to operating frequencies of ≤ 10 kHz. Given these limitations, designers are considering the optical feedback optocoupler.

Figure 9 shows a block diagram of a typical SMPS. The isolated feedback section can be viewed as an isolated piece of wire connecting the DC output to the control pin of the switch mode regulator. A simple design using a LM201 low-cost differential op-amp is shown in figure 10. R1 and R2 function as a voltage divider, dividing the +5 V supply output to 3 V. The servo/feedback photodiode sources a feedback current (I_{P1}) to R1 (30 k Ω). This resistor will develop 3 V when 100 μA flows through it. With $K3 = 1$, a similar value of 100 μA will flow through R5 (30 k Ω).

Thus I_{P2} of 100 μA will develop the 3 V DC signal needed by the control pin of the regulator. Figure 11 shows the DC response of this amplifier. Figure 12 shows the phase and frequency response.

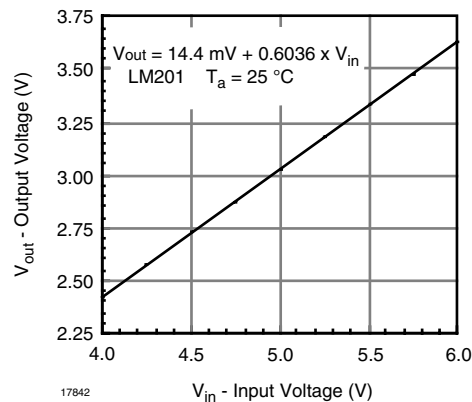

Fig. 11 - LM201 DC Transfer Gain

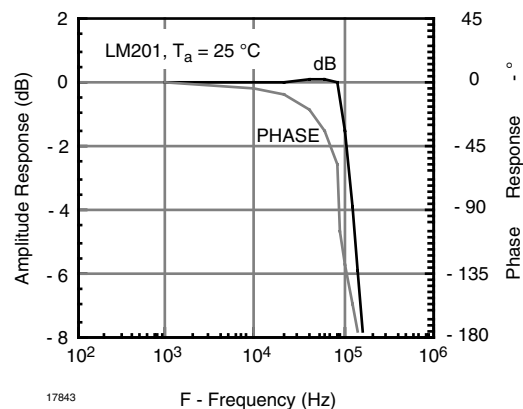

Fig. 12 - LM201 Phase and Frequency Response

This feedback circuit offers linearity and gain accuracy of $\pm 0.02\%$ over a 4.0 V to 6.0 V input (figure 13).

Optoelectronic Feedback Control Techniques for Linear and Switch Mode Power Supplies

Vishay Semiconductors

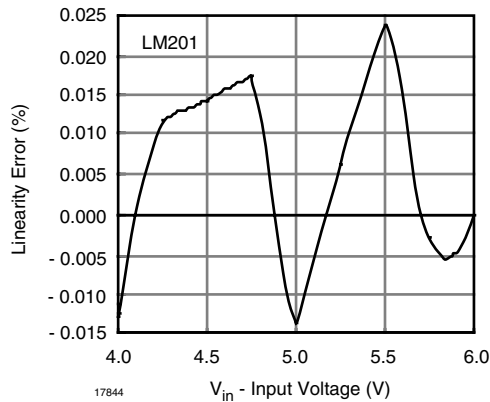

Fig. 13 - LM201 Linearity Error

The previous examples use differential amplifiers as the summing device. It is possible to configure a single-input DC amplifier that will perform the sample optical-servo control. One such design is shown in figure 14.

Figure 14 shows a DC-coupled current feedback amplifier. Q1 and Q2 form the gain stages. The feedback photocurrent, i_P , is supplied to the summing network at V_A . By inspection, the nodal equation indicates that the photocurrent will be that necessary to create a $2 V_{BE}$ drop across R1. The input resistor is also sourcing current to this node. Thus, as the input voltage rises, the photocurrent will drop. For this reason this amplifier functions as an inverting amplifier

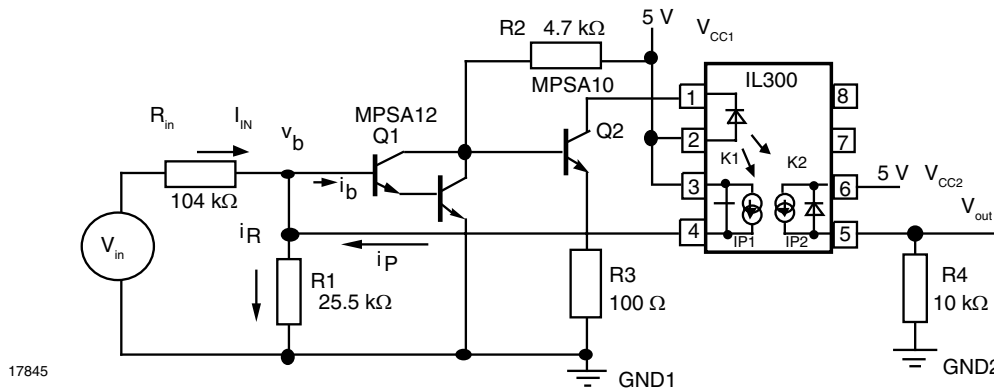

Fig. 14 - Discrete Isolation Amplifier

The frequency response and phase response for figure 14 is shown in figure 15.

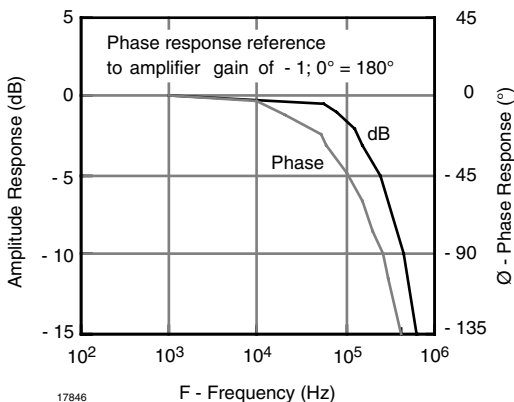

Fig. 15 - Discrete Isolation Phase and Frequency Response

Given this circuit's simplicity, gain accuracy and linearity are not compromised. The linearity error for this amplifier is $\pm 0.015\%$, as shown in figure 16.

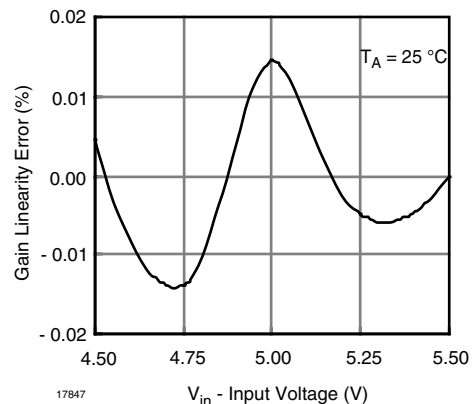

Fig. 16 - Discrete Isolation Linearity Error

Most power supply designers are familiar with TL431 and LM4041 precision adjustable zener diodes. When you look more closely at the internal operation of this device you will find that it too can function as a optical feedback amplifier for the IL300 (figure 17).

CONCLUSION

This application note was a generic presentation of the DC model of the standard phototransistor. Most designers have overcome many of standard phototransistor's temperature and initial gain variations by selecting well-specified couplers such as the CNY17-X family.

When wider bandwidth and greater gain stability is required, power supply designers are using the new optical feedback linear optocouplers. The circuits provided and their performance characteristic will satisfy even the most demanding high-frequency SMPS applications.

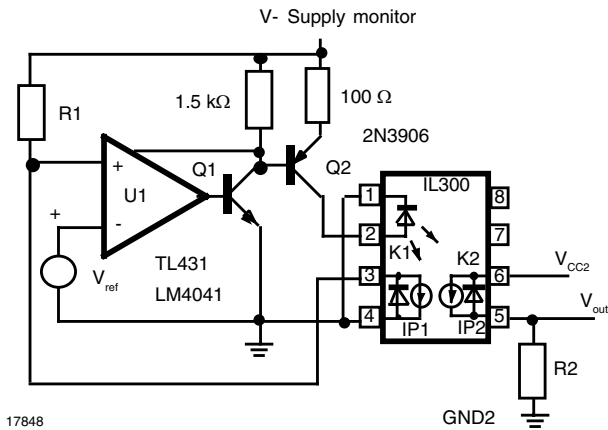

Fig. 17 - Shunt Voltage Regulator

The three terminal regulators include U1, Q1, and the precision reference, V_{ref} . The linear coupler will supply sufficient photocurrent to develop a difference voltage across R1. The transfer equation for this amplifier is given in equation 9:

$$\frac{V_o}{V_{mon} - V_{ref}} = \frac{R_2}{R_1} \times K_3 \quad (9)$$

The precision voltage reference (V_{ref}) is 2.5 V for the TL43. When lower voltage supplies, i.e. 3.3 V, are to be regulated, the new LM4041 with a reference of 1.225 V can be used.

The designer may be more familiar with the circuit schematic shown in figure 18.

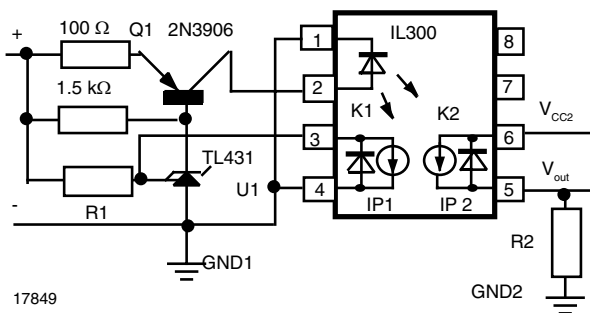

Fig. 18 - Shunt Voltage Regulator Isolation Amplifier